



Queen's University
Belfast

Maintaining our Grasp on Reality - Are Design Processes and CAD Models fit for purpose?

Professor Mark Price

12th June 2014

School of Mechanical and Aerospace Engineering

Overview

- Context and Background
 - Why is this an issue?
- Features and Parameters
 - What is the difference and why does it cause problems?

Begin at the beginning," the King said, very gravely,
"and go on till you come to the end: then stop."

— Lewis Carroll, *Alice in Wonderland*



Context & Background

Complex Machines – Complex Decisions



Fuselage Structure

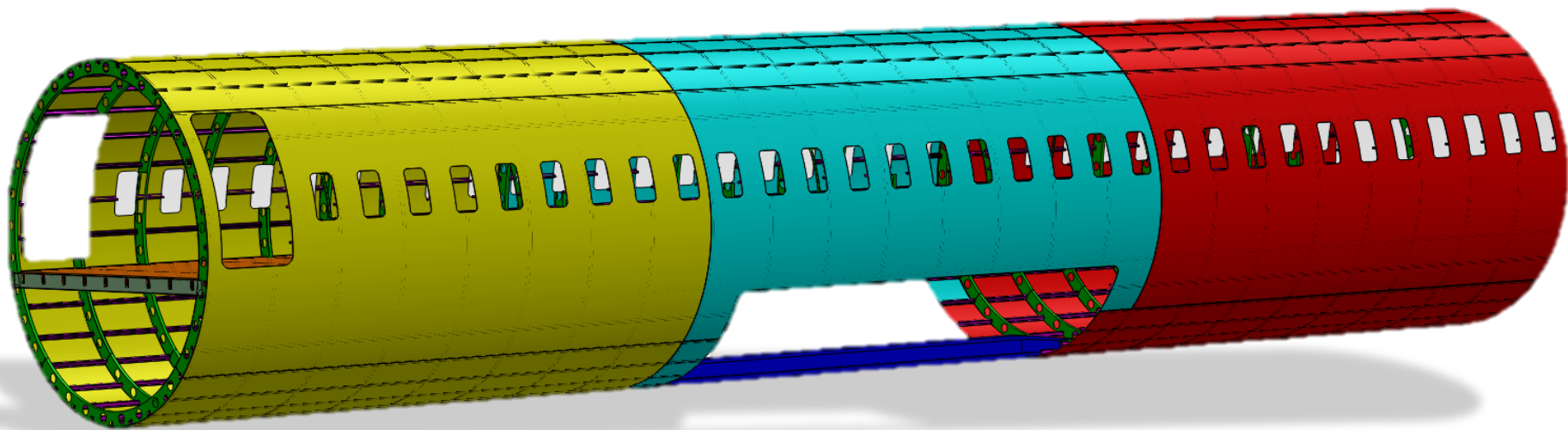

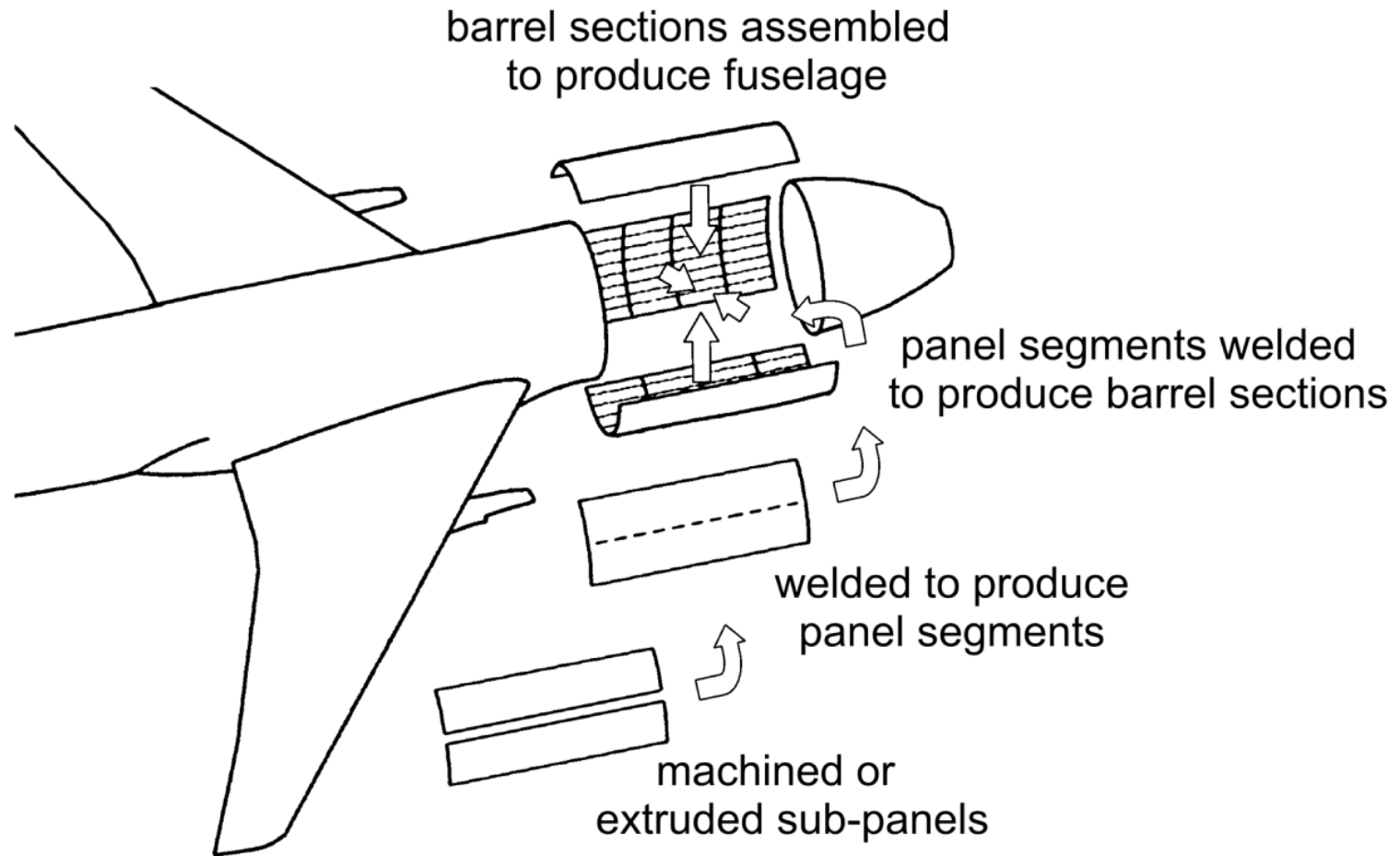

Structures

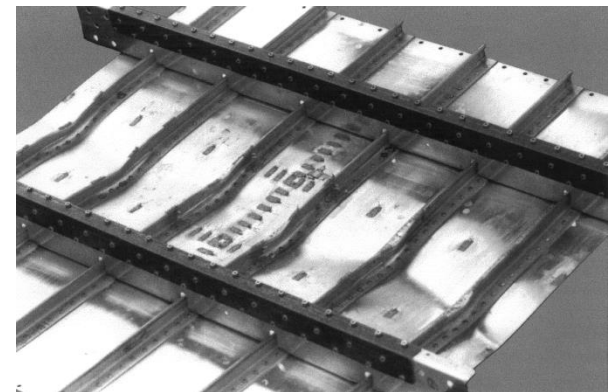
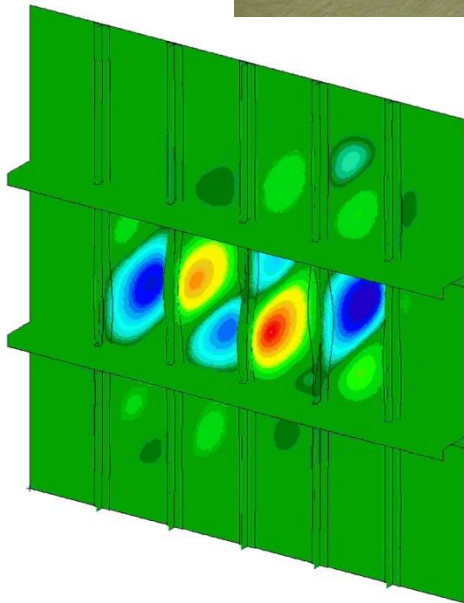

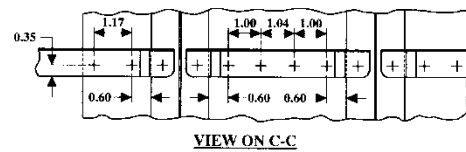
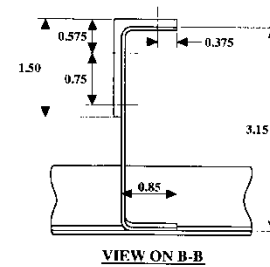
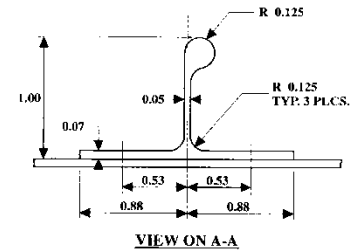
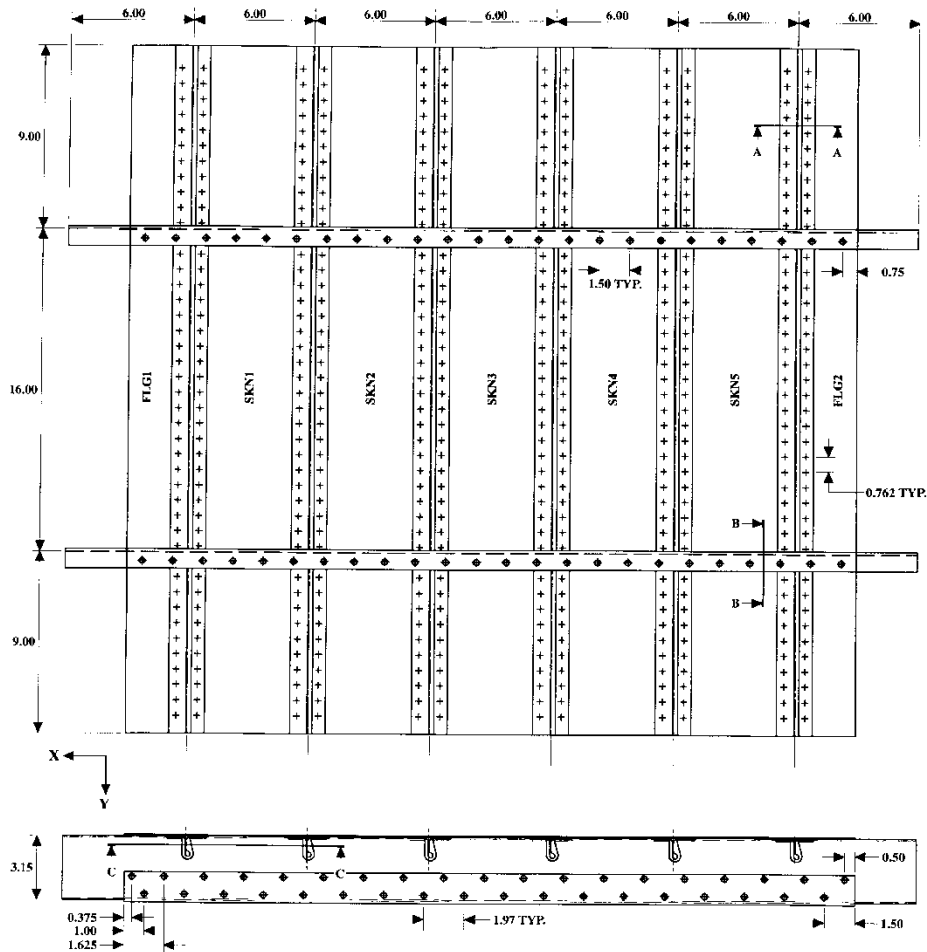

NOTES

1. ALL DIMENSIONS IN INCHES
2. + = MS20426 100 DEG CSK RIVET
3. ⊕ = 2BA BOLT
4. SKIN - 2024-T3 0.063 THK
5. FRAME SECTIONS - 7075-T6 0.05 THK
6. STRINGERS - 2024-T811 EXTRUSIONS
7. FRAME REINFORCING ANGLES - MILD STEEL 0.118 THK

Shear-Compression Test Rig

500kN
Compression

400kN
Shear

Panels
1.5m x 1.5m

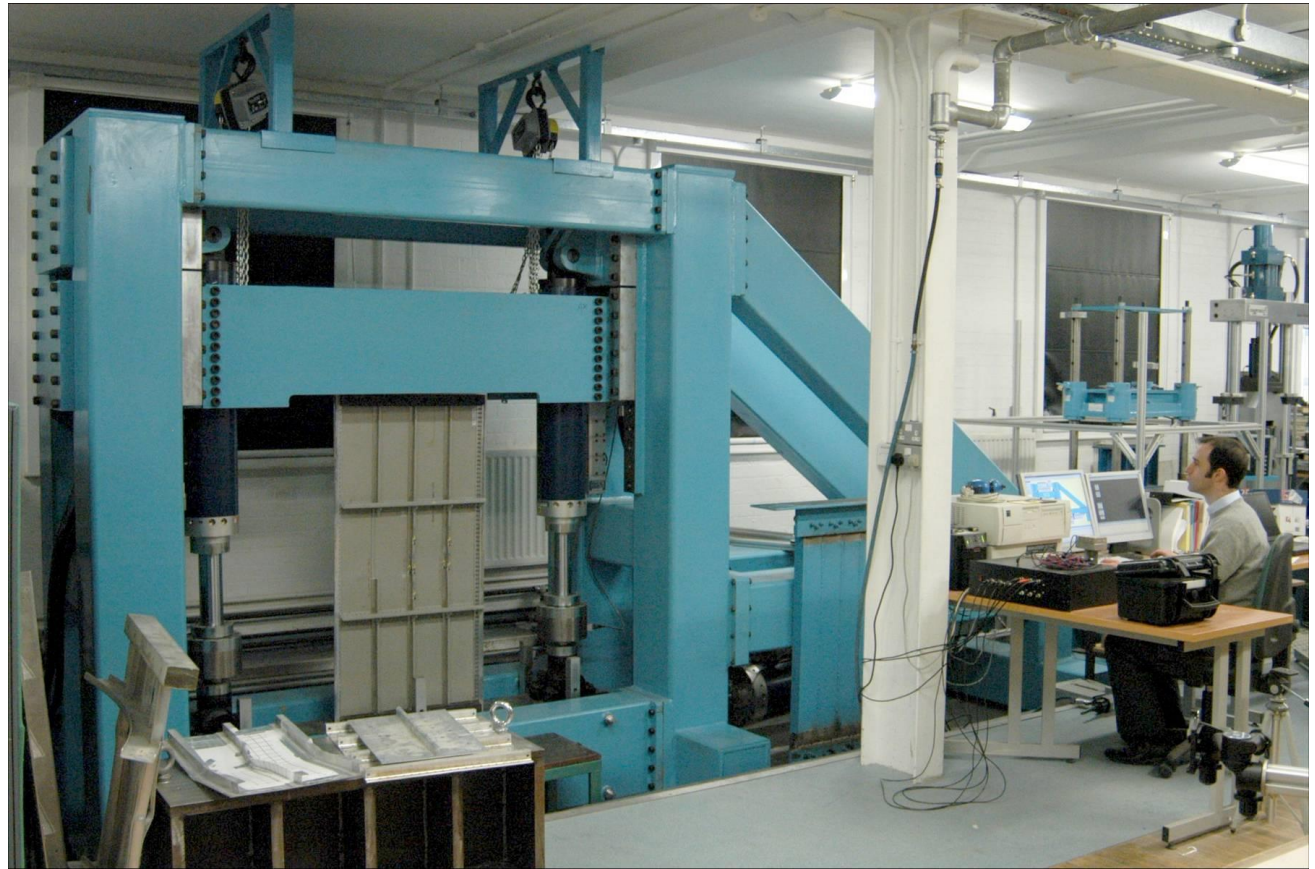

Virtual Testing

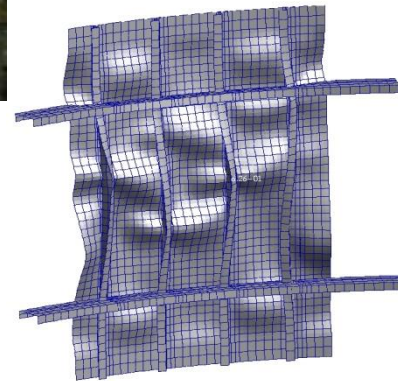
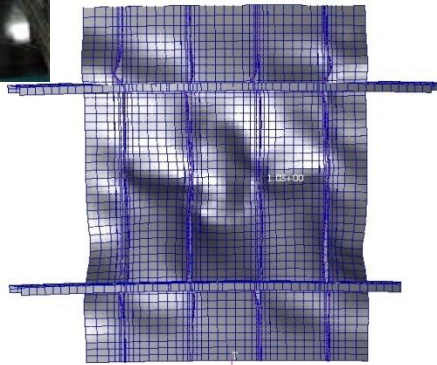

Advanced computer simulation allows virtual testing of the new concepts to quicken the selection of the most promising.

Integrated Design and Manufacturing

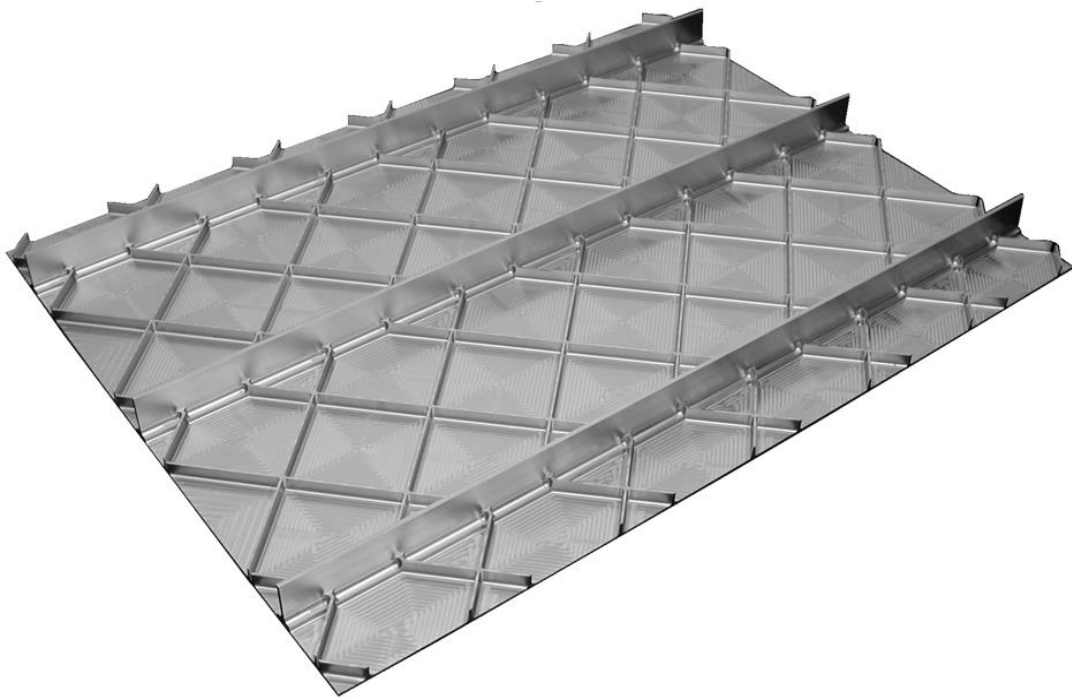

New manufacturing concepts such as laser beam and friction stir welding, and panel profiling, can result in lighter, cheaper airframes. (with Alcan France)

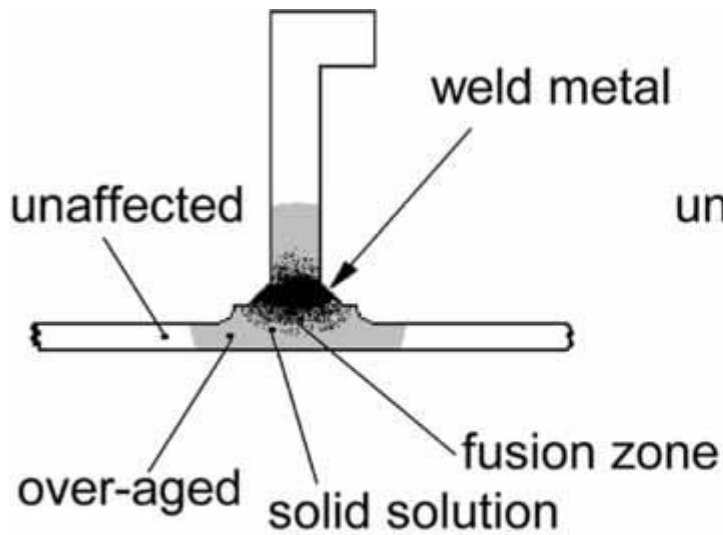

a) Laser beam welded section.

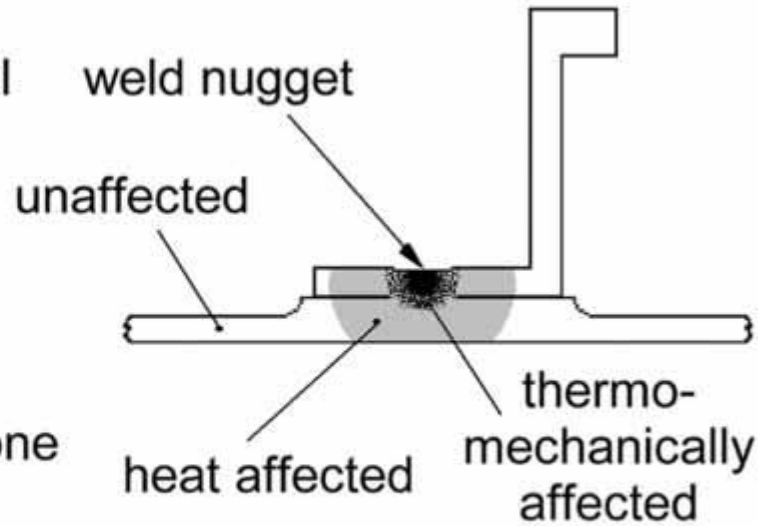

b) Friction stir welded section.

a) Fully factored:

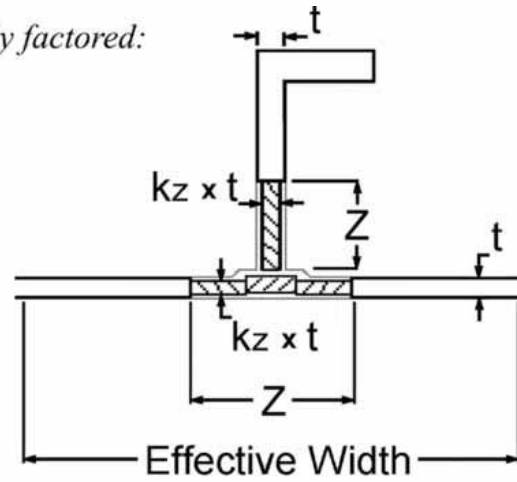

b) Parallel factored:

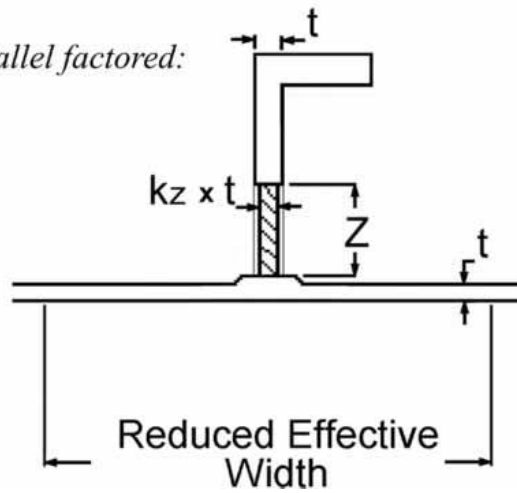

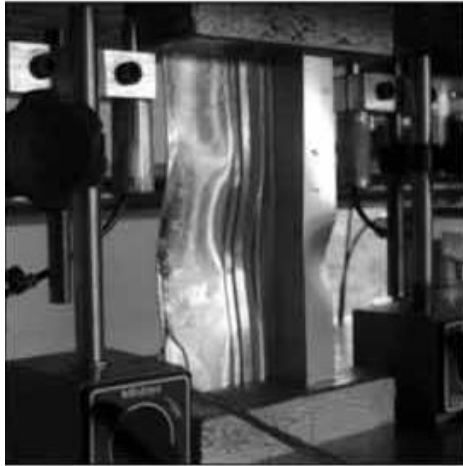

non-contact
model



contact
model

b) Friction stir welded (Specimen FS2)

Load-Displacement Curves

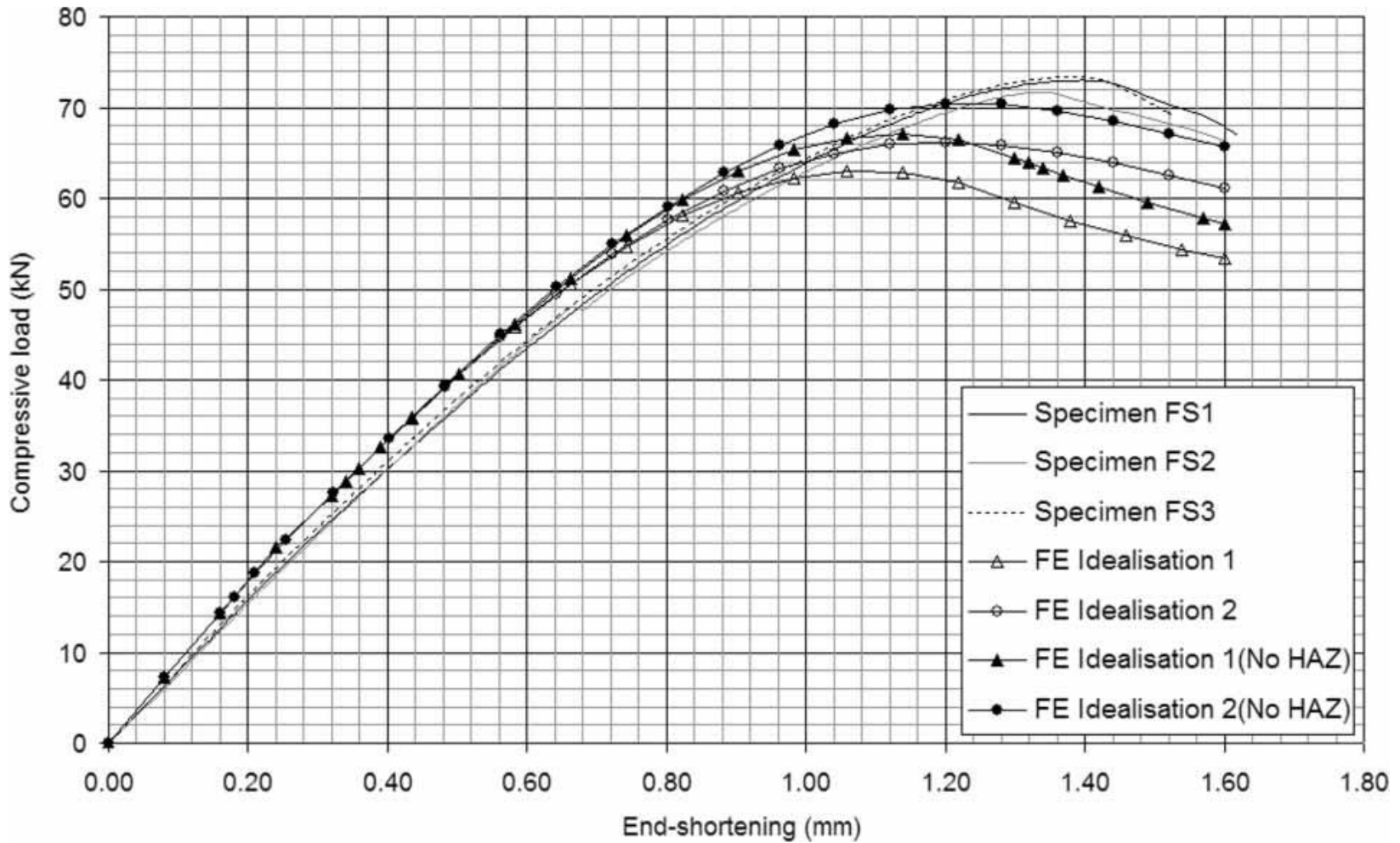

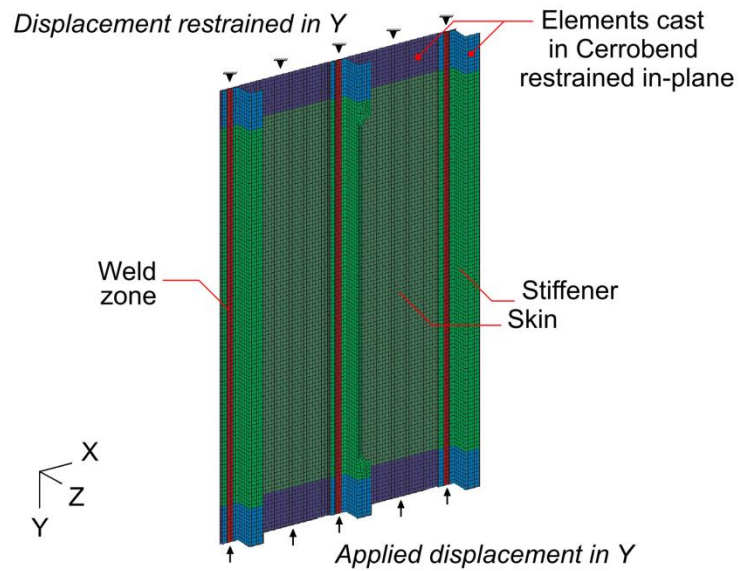
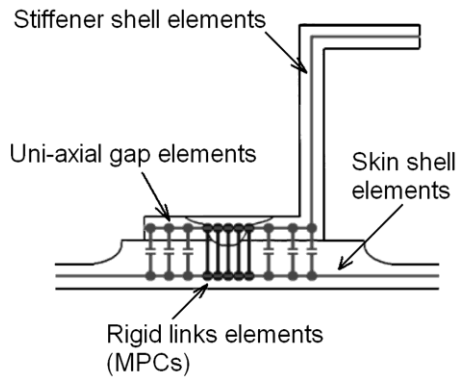

The devil in the detail!

Single frame bay specimen

	Edge stiffeners [welded] (mm)	Central stiffeners [welded] (mm)
h_s	25.4	25.4
b_{ff}	20.3	7.3
b_{af}	22.9	22.9
t_w	1.6	1.6
t_{ff}	1.6	1.6
t_{af}	1.6	1.6
t_{skin}		1.2

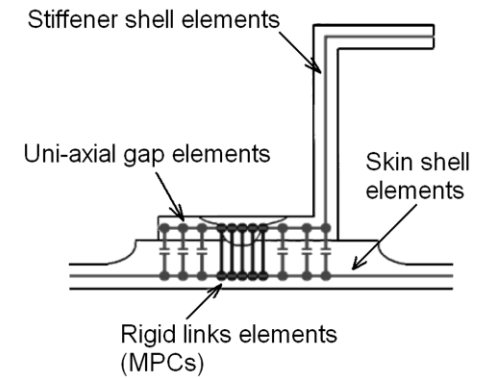
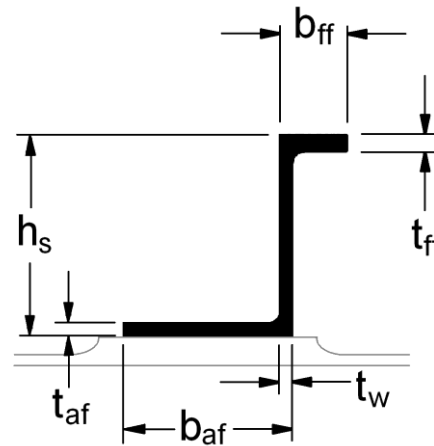

Key Issue: Stiffener-Skin Interface

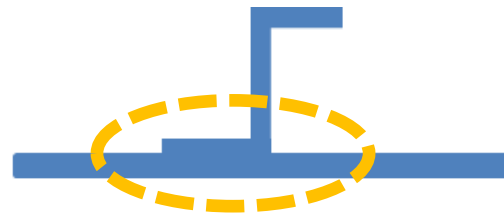

(a) Idealised Stiffener on plate



(b) Riveted Stiffener
(assembled)



(c) Integral Stiffener
(extruded or machined)



(d) Laser welded Stiffener
(assembled)



(e) Friction Stir Welded Stiffener
(assembled)

Different minimum weight solutions are found for each of these.

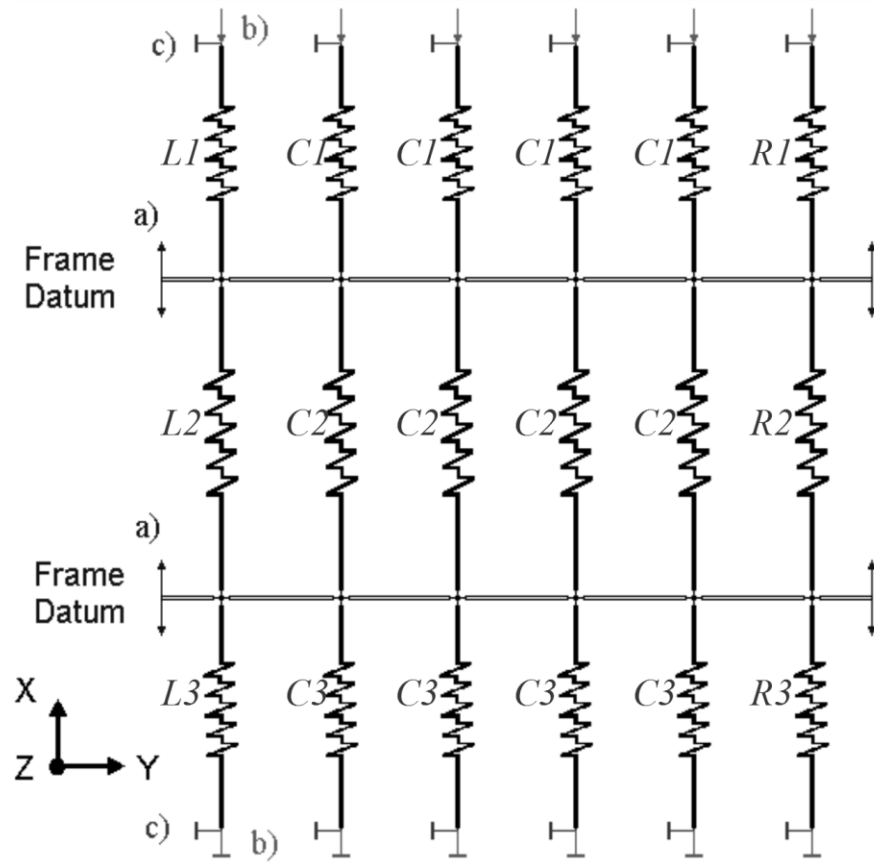

- a) → Frame datums allow to translate axial in-plane
- b) → Model axial loading & restraints
- c) → Model rigid body motion restraints

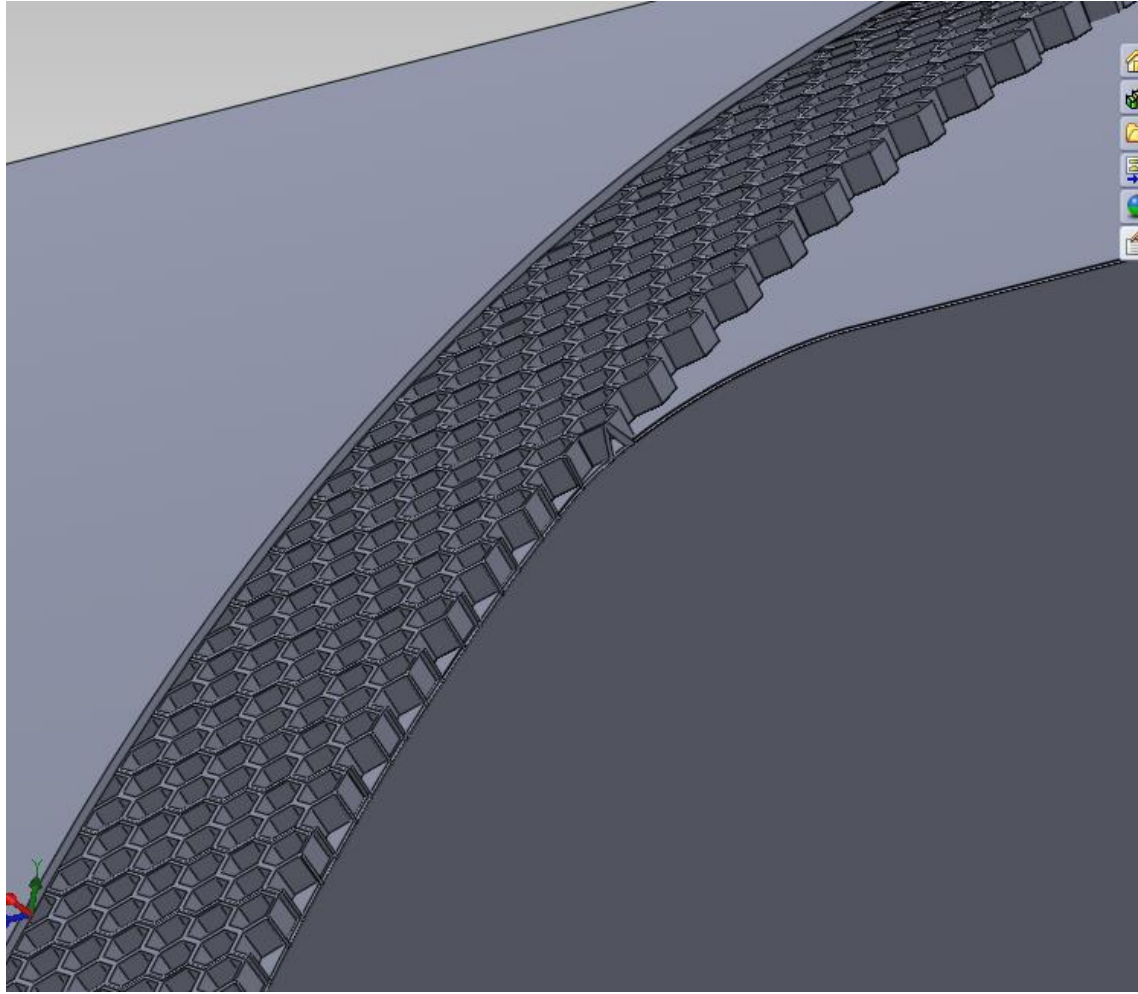

Problem

- Design is about creating real products
 - Things that get made!
- Fundamentally it is defining geometry for manufacture
 - Of course also operations etc
- Sophisticated processes and tools
 - Systems engineering, CAD, CAE CAM.....
 - Powerful feature based modelling systems

- Design Intent

“..a set of geometric and functional rules that the final product has to satisfy.”

(Mun)

or

“The set of functions which the system was designed to deliver in the anticipated operating environment”

(QUB)

Features and Parameters

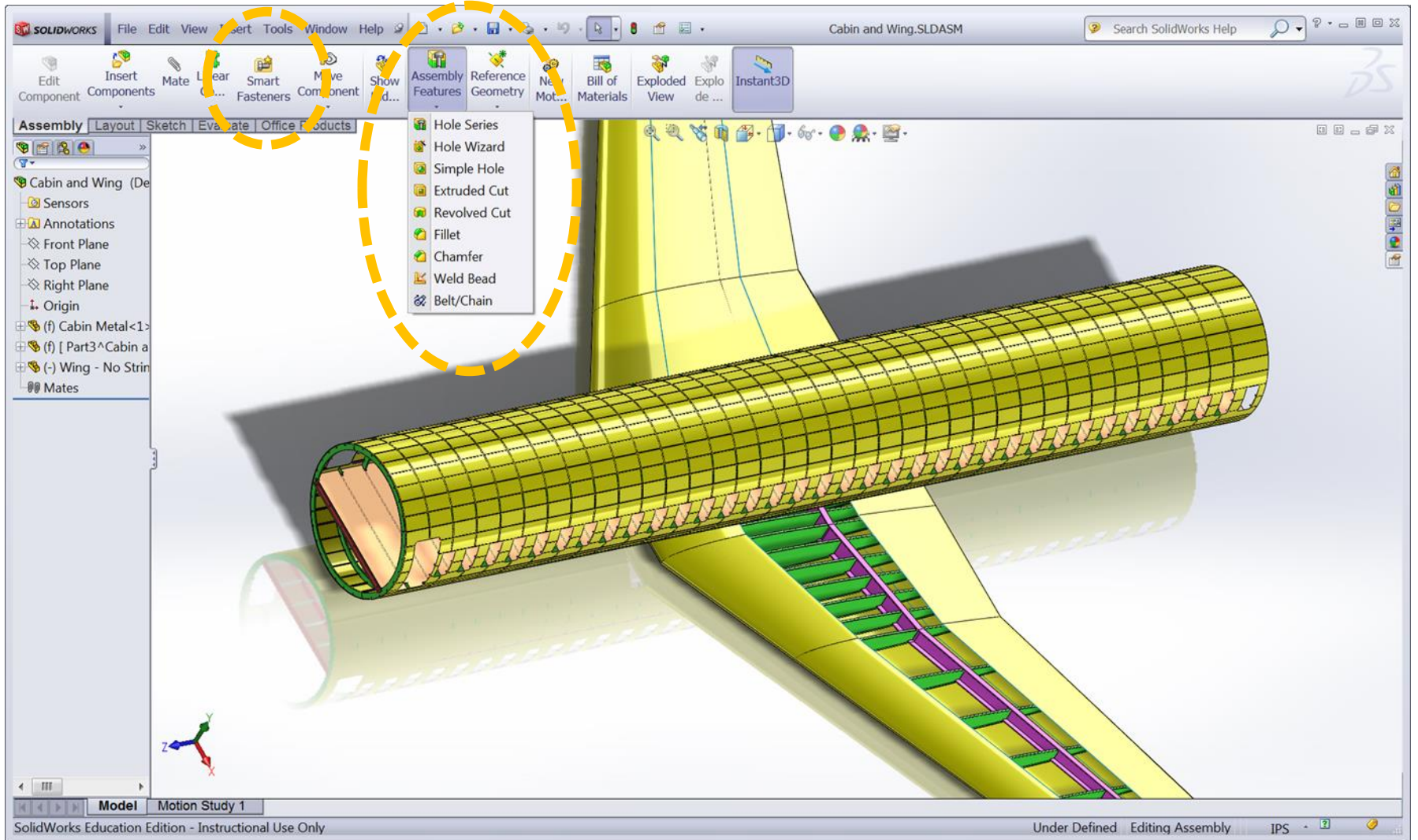

The Face Off

- The Process vs the Product
 - How the model is built
 - How it looks in it's final form

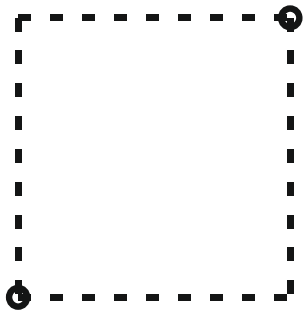

(a)

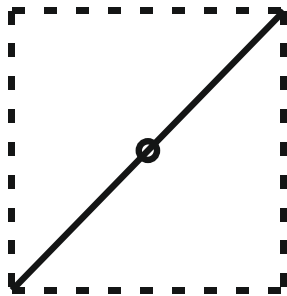

(b)

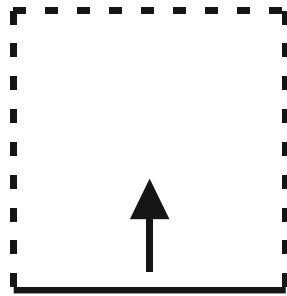

(c)

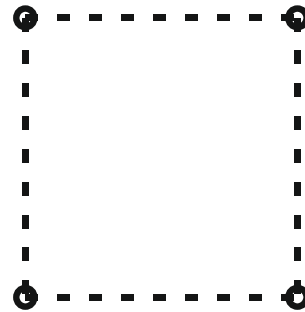

(d)

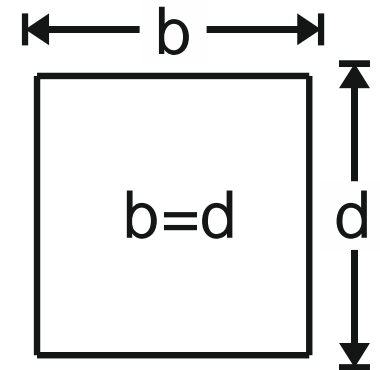

(e)

- Parameters....

“..the designer’s choice of parameterisation and constraint schemes constitutes an important part of what is known as design intent”

(Anderson)

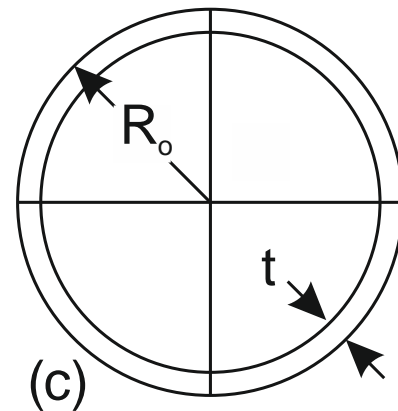
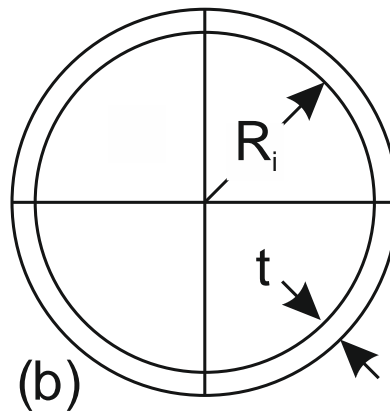
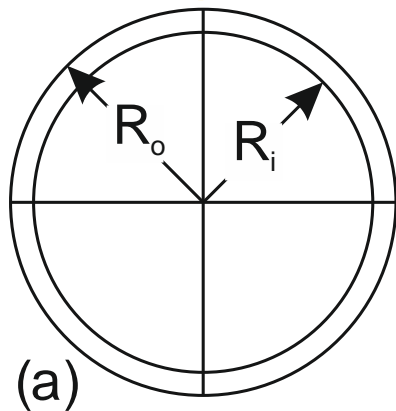

Back to the Fuselage

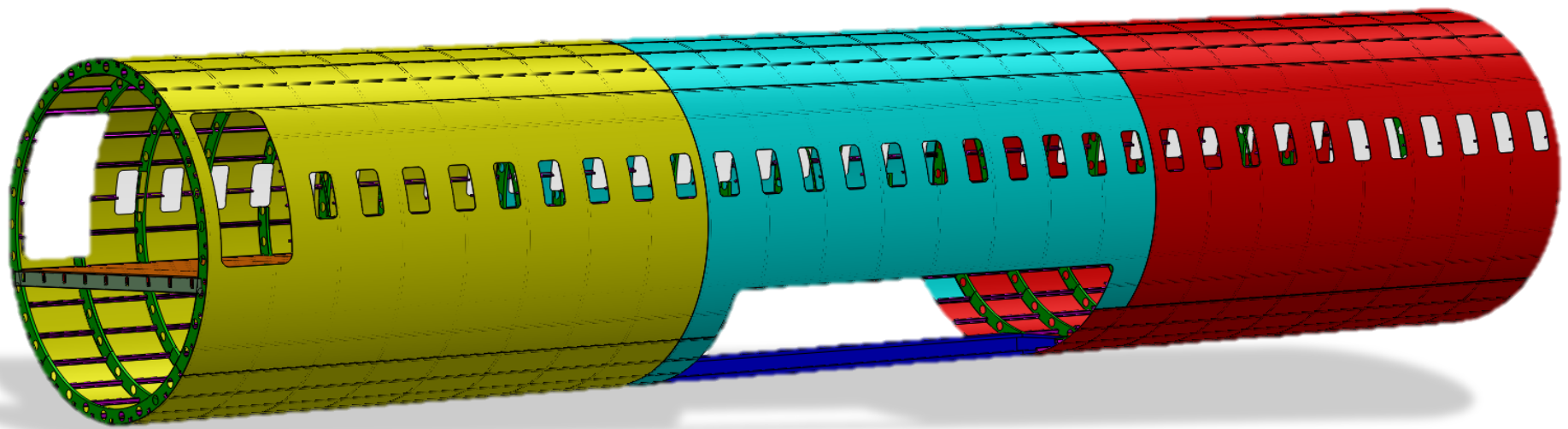

- CAD Feature tools help the designer to create geometry (and features) quickly
- No account taken how it is to be manufactured.....

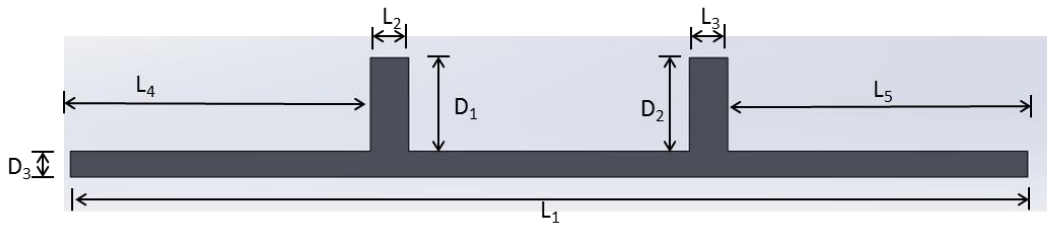
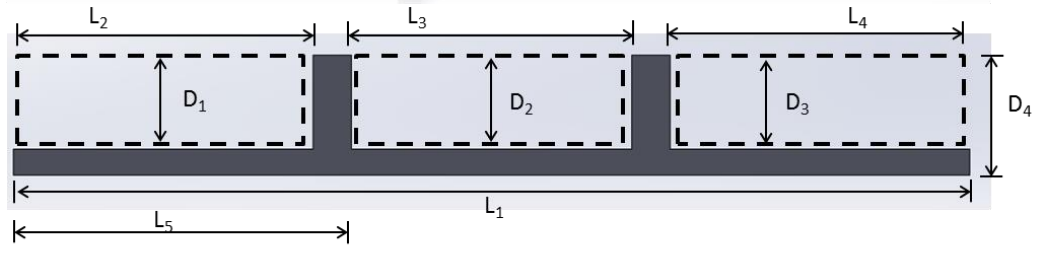
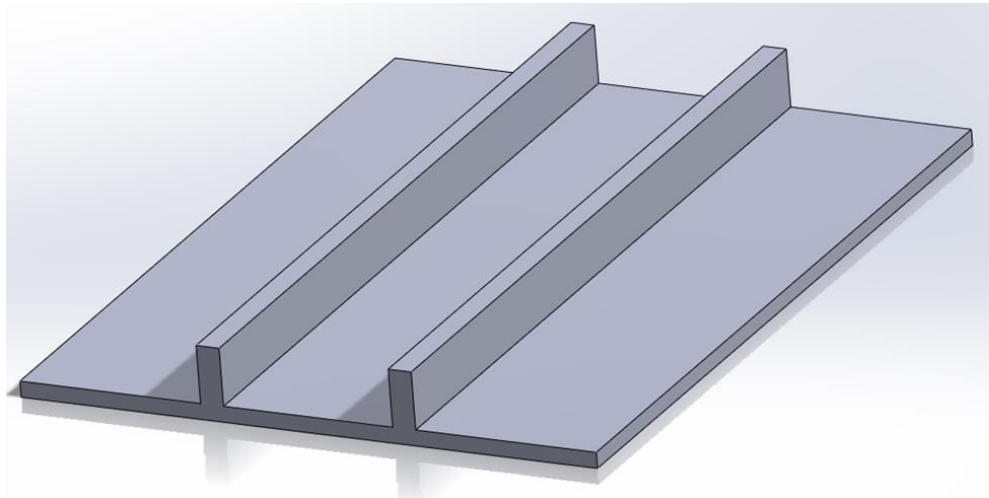



(a) Idealised Stiffener on plate



(b) Riveted Stiffener
(assembled)



(c) Integral Stiffener
(extruded or machined)



(d) Laser welded Stiffener
(assembled)



(e) Friction Stir Welded Stiffener
(assembled)

Why, sometimes I've believed as many as six impossible things before breakfast.”

— Lewis Carroll, *Alice in Wonderland*

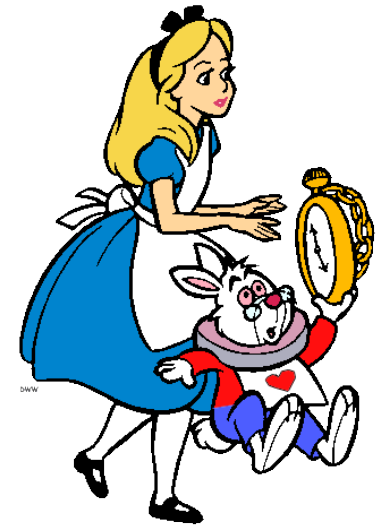

Where does this all fit in a design process?

- Prediction using Newton.....

$$\sum F_y = 0$$

- But formula become more complex as we look deeper into problems

- E.g. beams

$$\text{Load} = W(x)$$

$$S = \int W dx$$

$$M = \int S dx$$

$$\theta = \int M dx$$

$$y = \int \theta dx$$

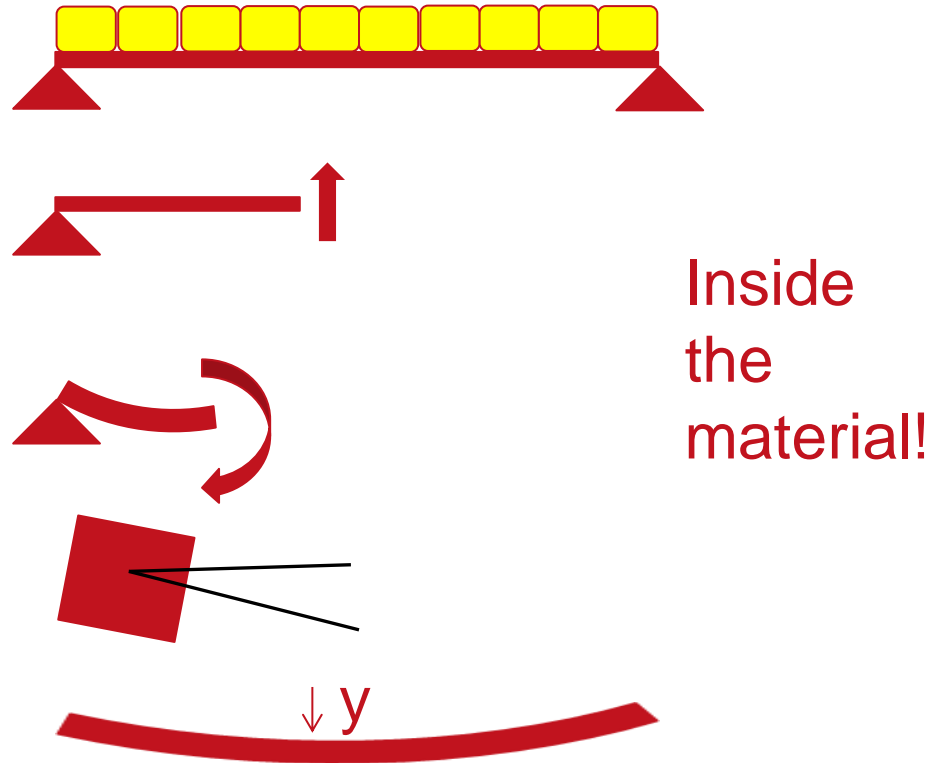

How do you eat an elephant?

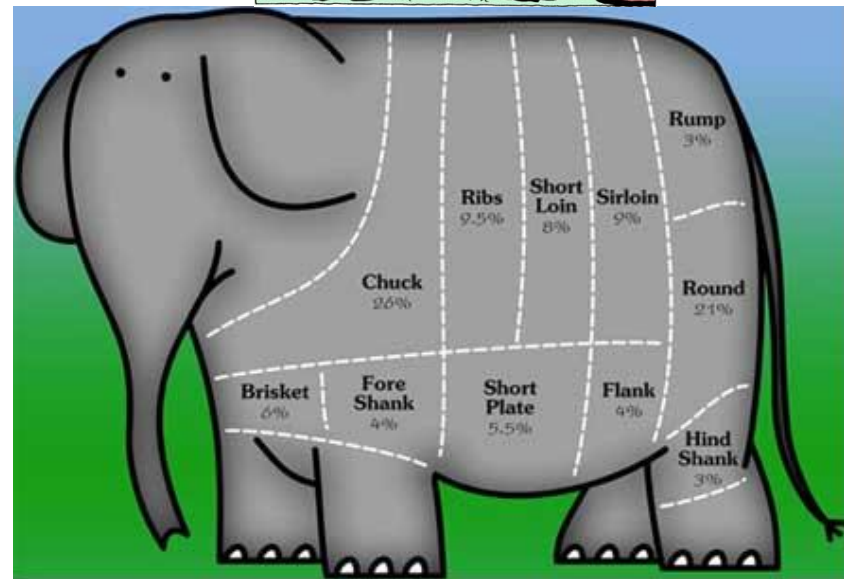

Same for Complicated Machines

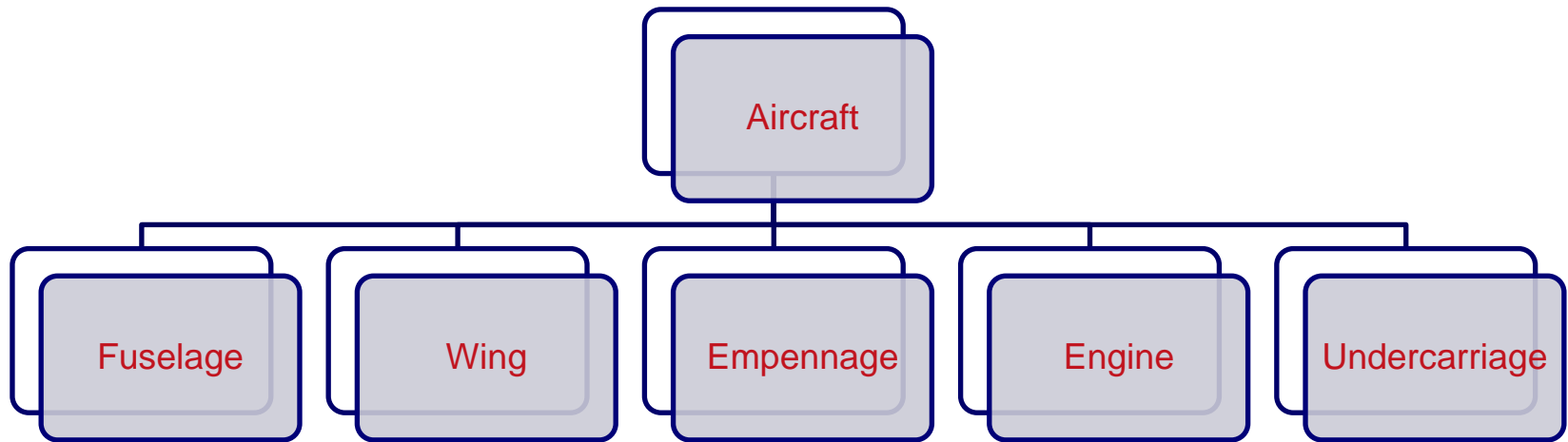

Components can be complex in shape



Very challenging for complex shapes

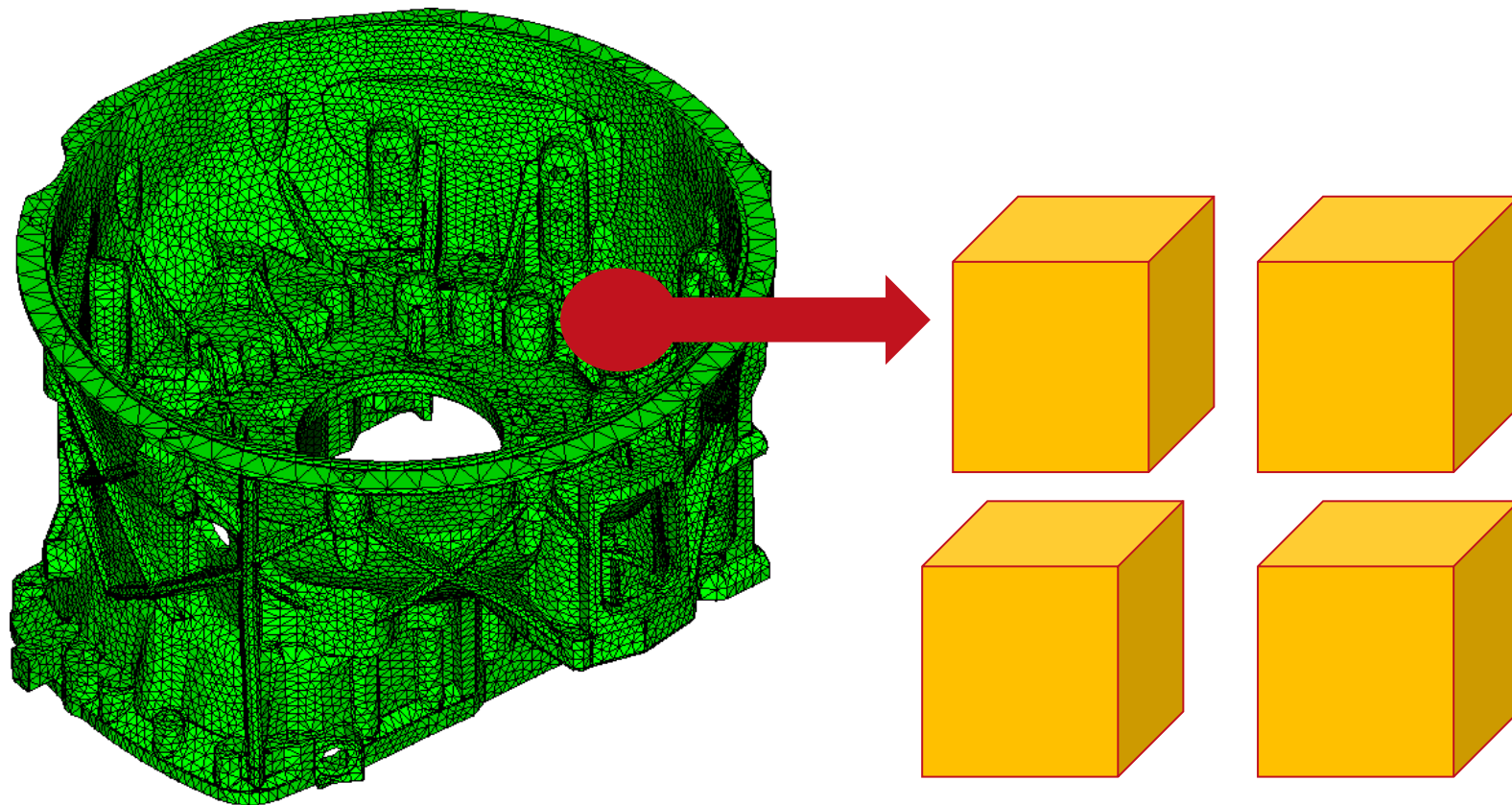

Idealisation & Model Simplification

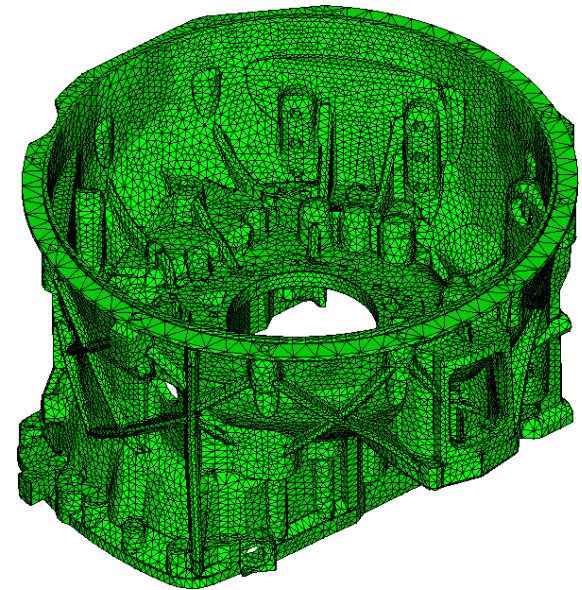
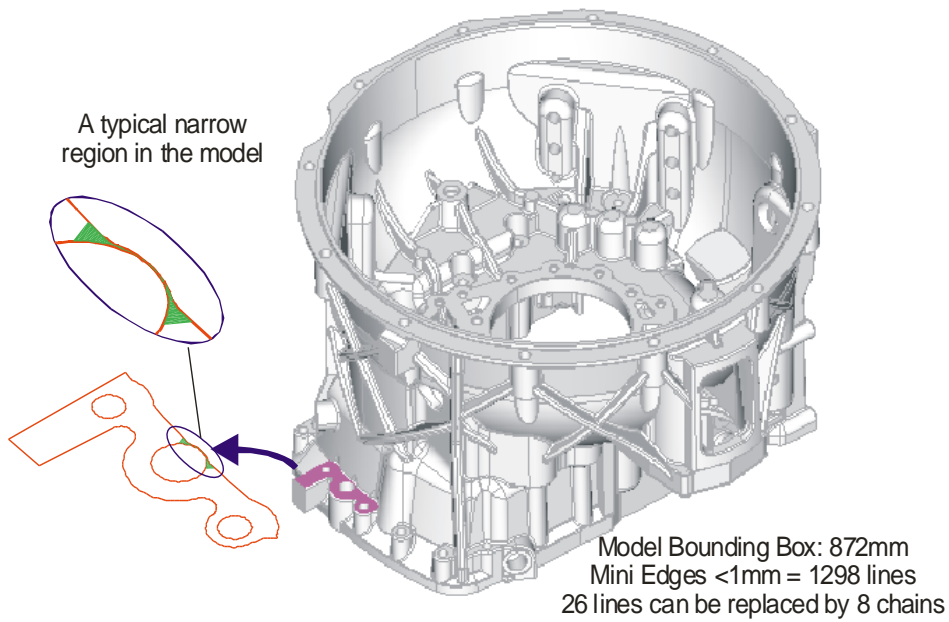

“What I cannot create, I do not understand. Know how to solve every problem that has been solved.”

Richard Feynman

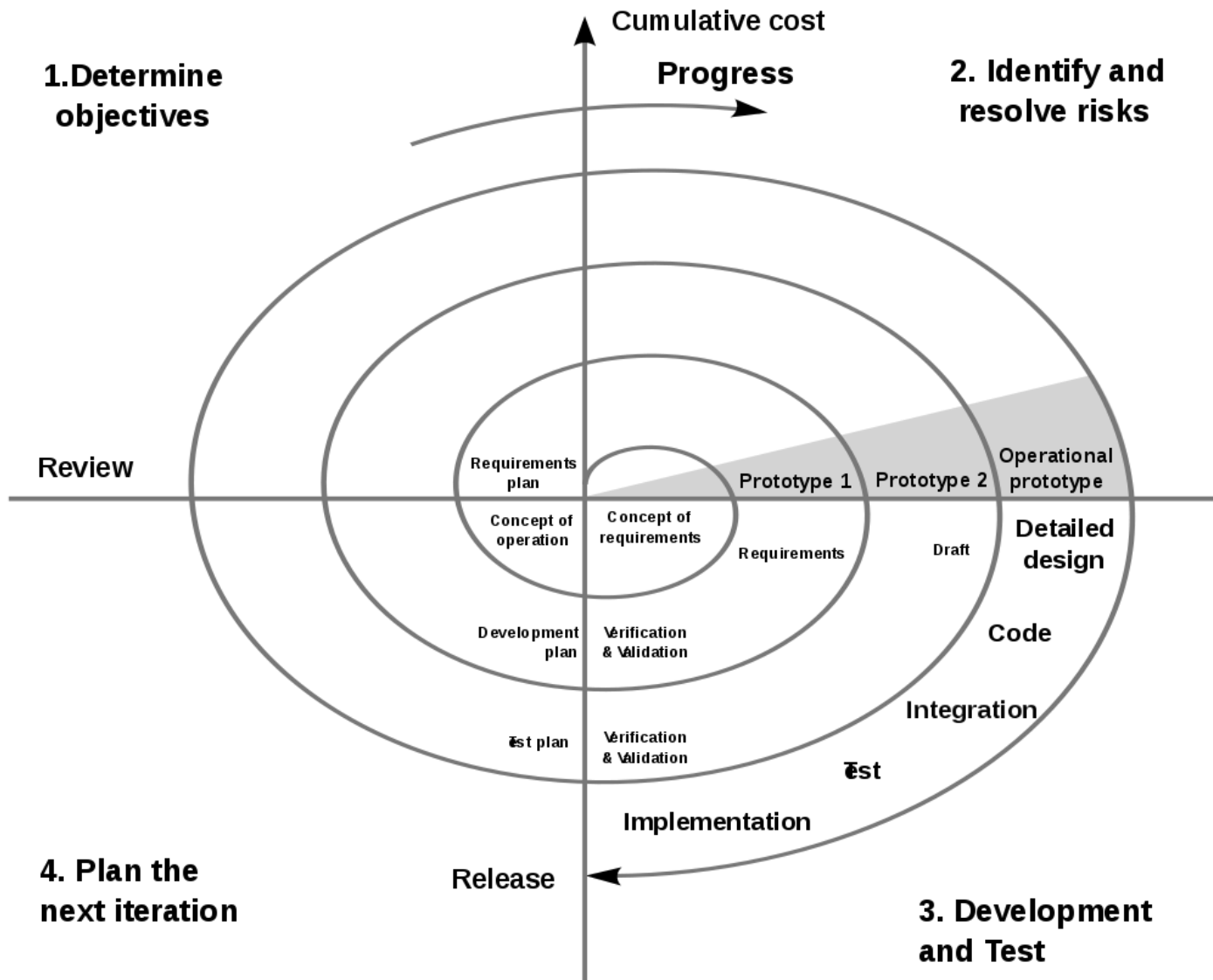

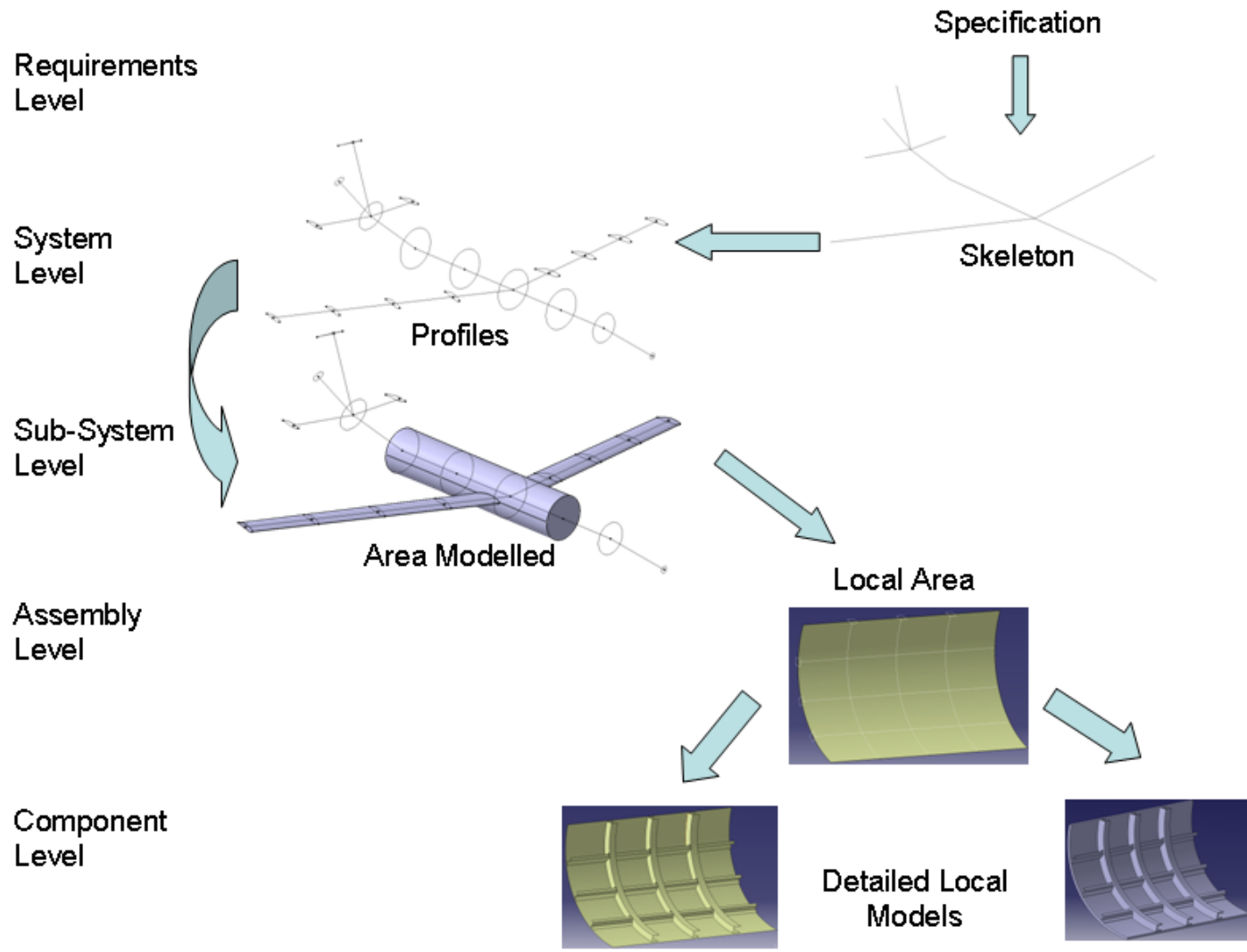

Correct placing & relationships

The fuselage is reinforced with frames and stiffeners

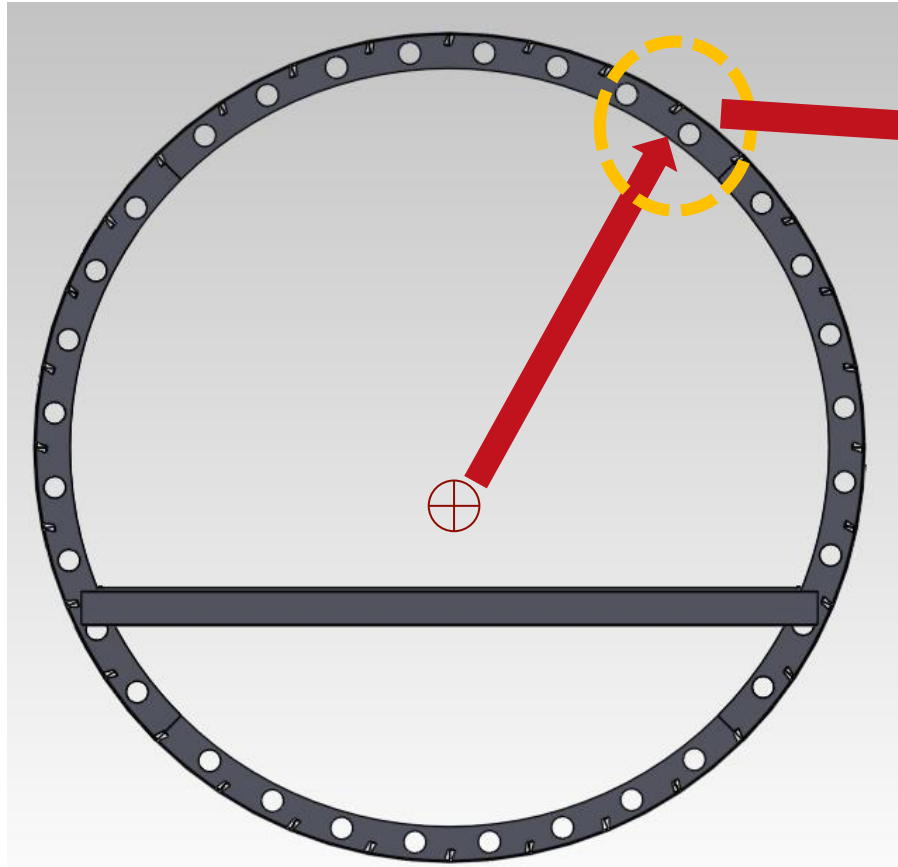

The stiffeners are placed relative to the neutral axis of the fuselage.

Designers sketch & analysts idealise

Function (Intent) of the stiffener is to carry end load and a little (but preferably no) bending, supporting the skin.

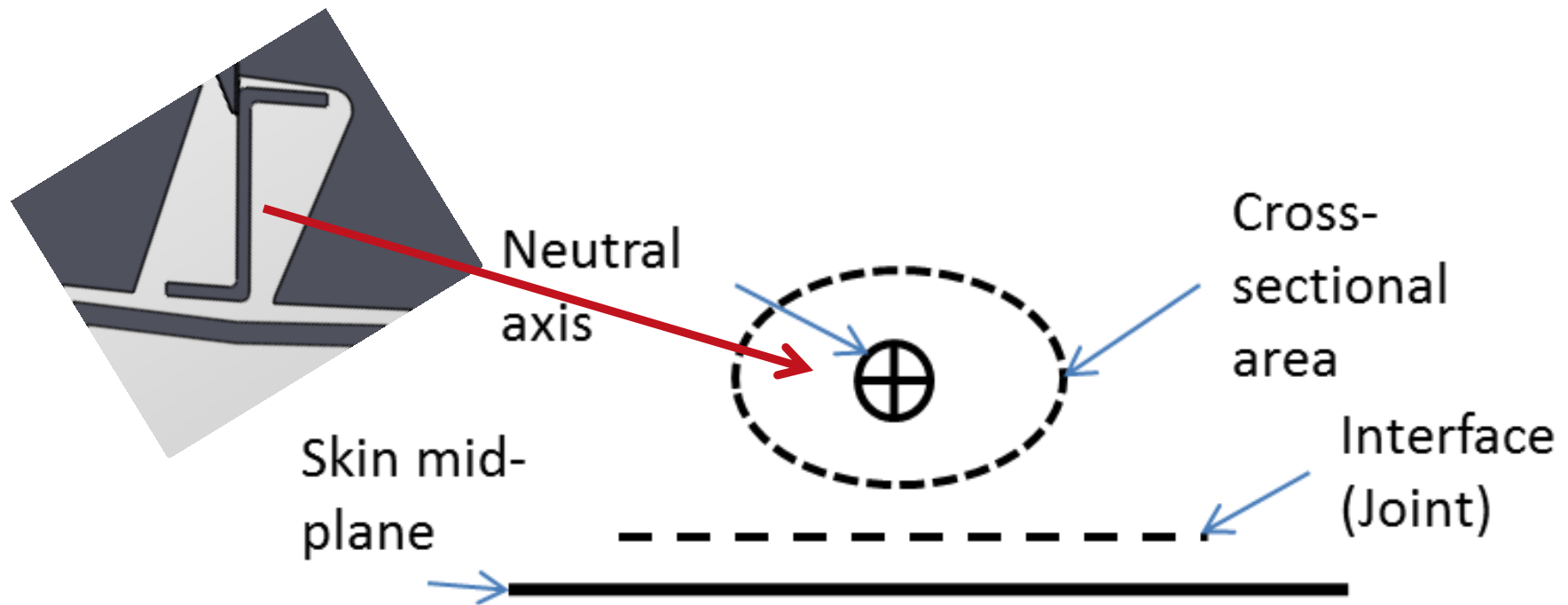

Implications of assemblies

- Implies integration of manufacturing processes in design
- Consideration of cost, resourcing, planning, maintenance etc
- It is a problem with many dimensions

Integrated System Functions

$F(x, y, z, t, \text{cost, material, process...})$

What we can see in 3D

N-dimensions



Constraints limit the size & shape in 3D

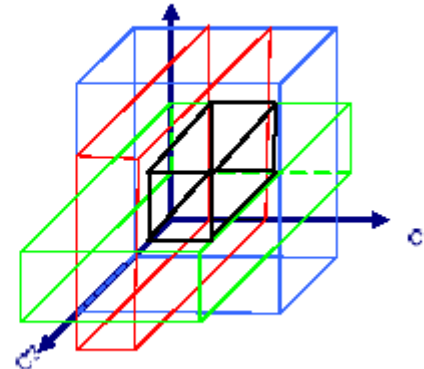
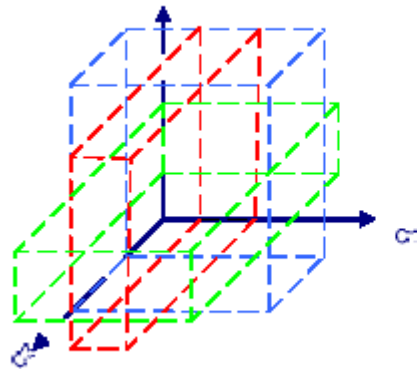
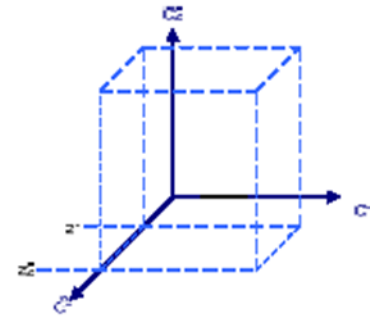
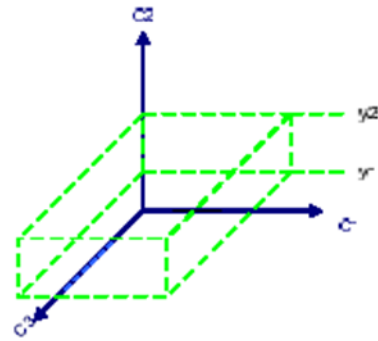
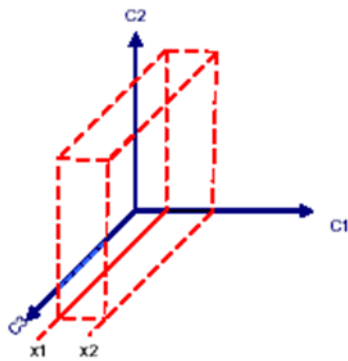

Example of square showing cost & size in different areas

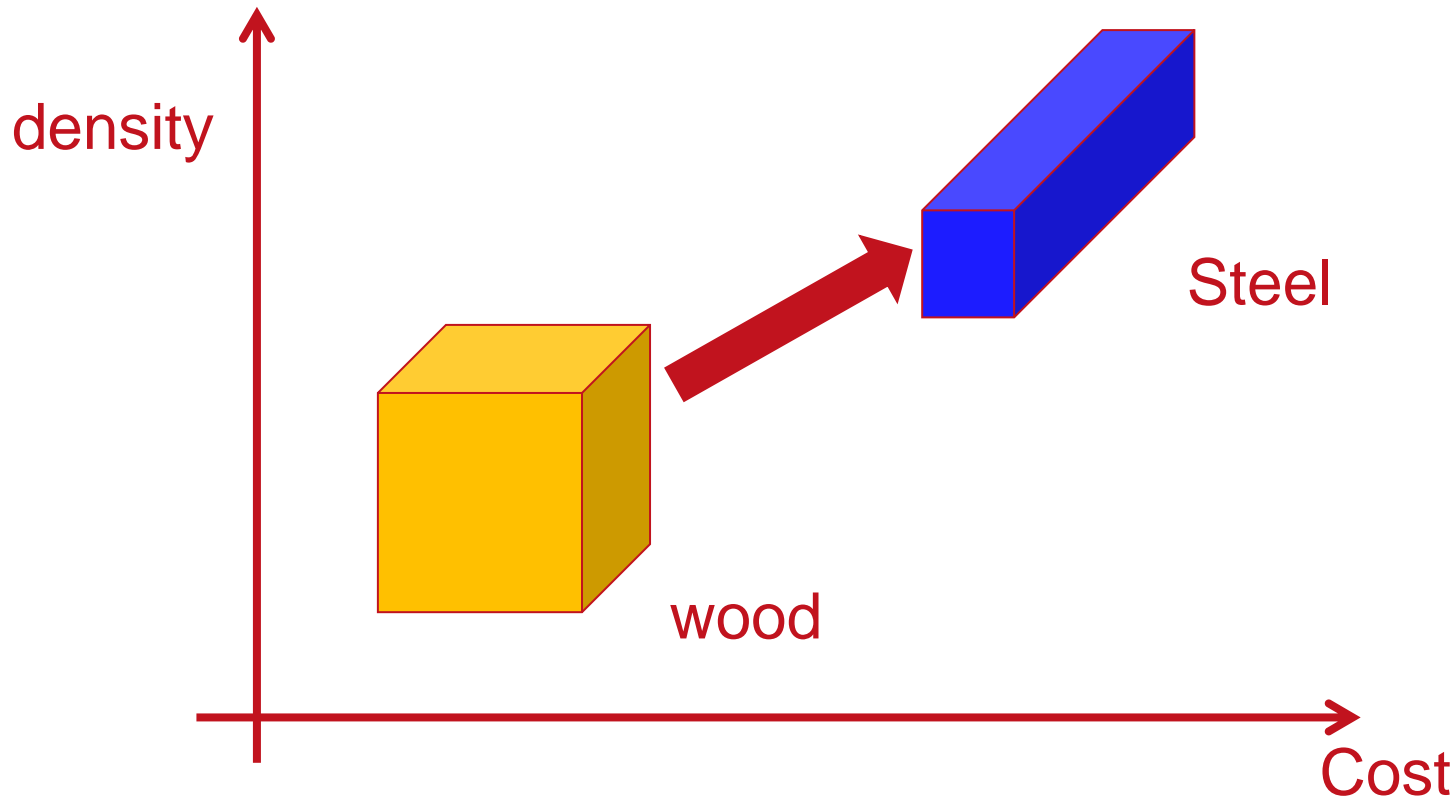

The physical shape may change due to other parameters, such as cost & weight

Constraints impact shape

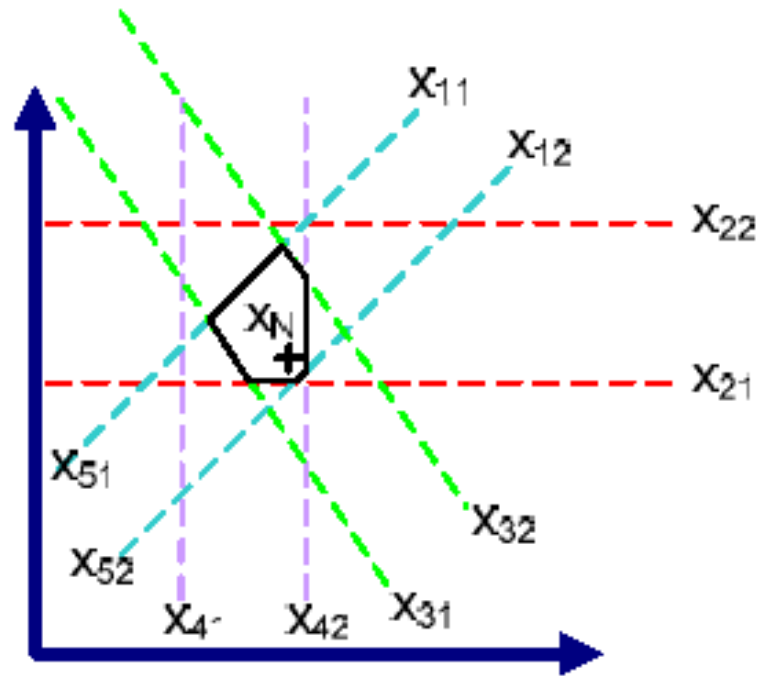

Projection of 5-D design space in 2D with and without uncertainty factor applied to constraints

Now think about manufacturing

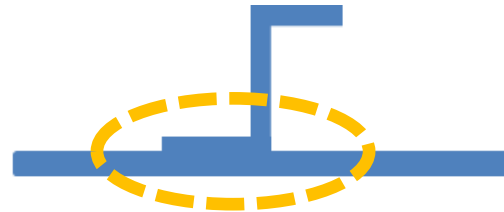

(a) Idealised Stiffener on plate



(b) Riveted Stiffener
(assembled)



(c) Integral Stiffener
(extruded or machined)



(d) Laser welded Stiffener
(assembled)



(e) Friction Stir Welded Stiffener
(assembled)

*Different
minimum
weight
solutions are
found for each
of these.*

Plate - Parameterisations

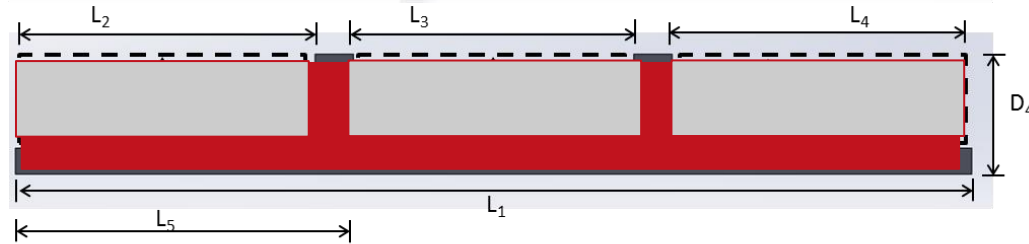
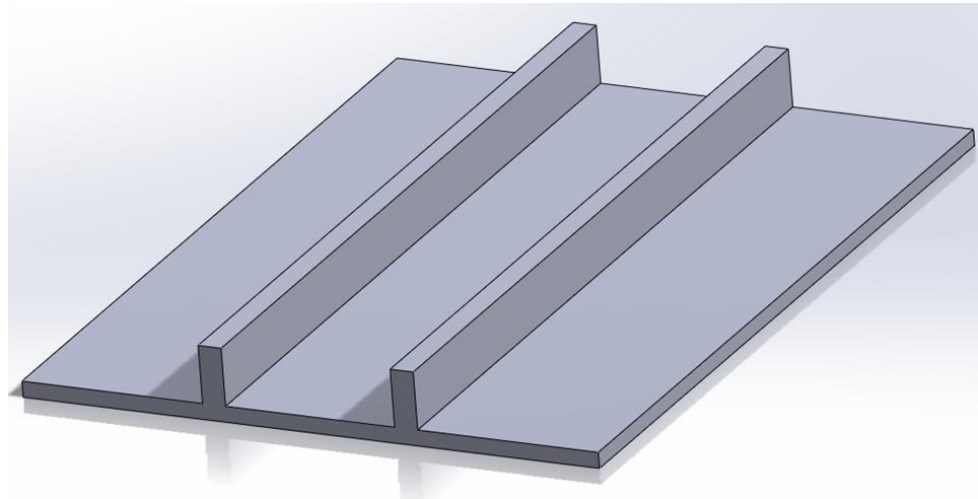

Machine
from a
block

Weld

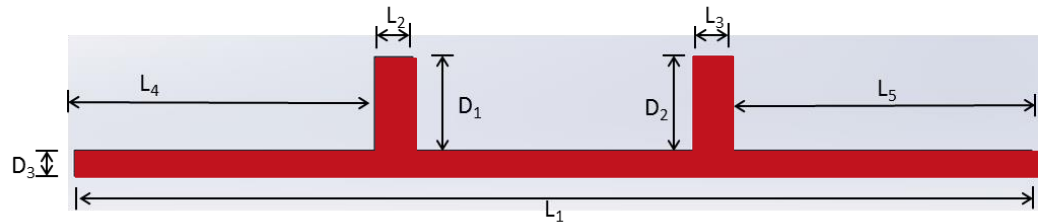

Integrated Design and Manufacturing



New manufacturing concepts such as laser beam and friction stir welding, and panel profiling, can result in lighter, cheaper airframes. (with Alcan France)

C-Series Wing ~13,000 tests!

-> 1 vehicle, small number of material configurations

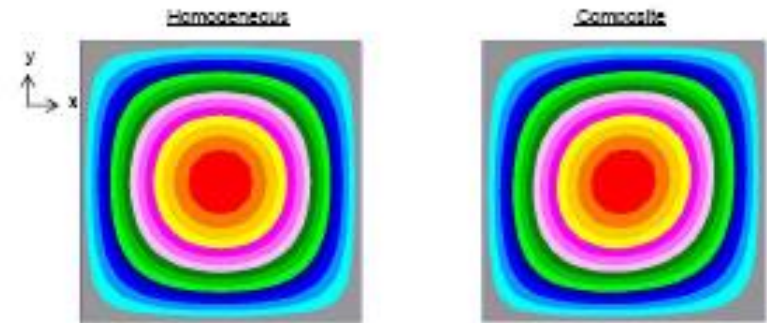

Figure 4-7 First buckling mode shapes for quasi-isotropic laminate

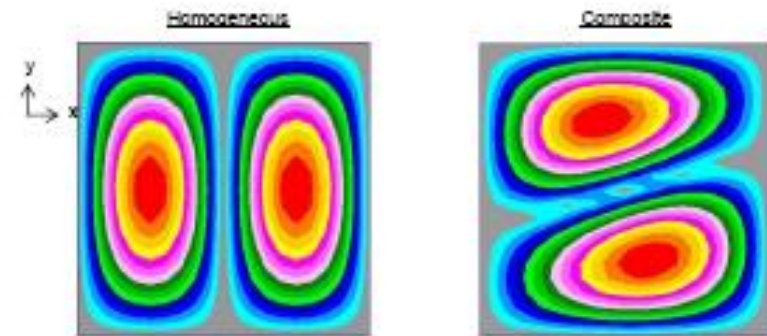

Figure 4-8 Second buckling mode shapes for quasi-isotropic laminate

Stress and displacement patterns are different in composites

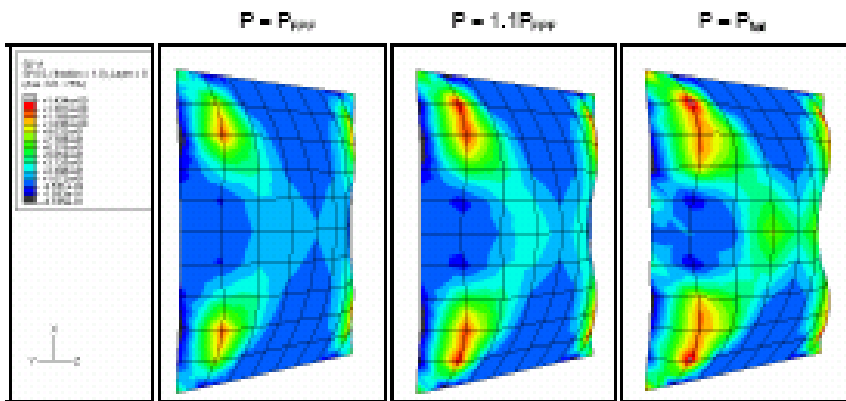

Figure 4-27 Contours of matrix failure index of crossply laminate, $AR = 1.2$

Failure locations are not always obvious

Questions!

- Identify the limitations of the CAD technology and integration of additional problem dimensions?
- A consistent parameter set representing the appropriate capability for design, analysis and manufacturing?
- A consistent modelling process for design, analysis and manufacturing?
- What is our confidence that validation testing is genuinely validating operational behaviour?
- What is the cost/confidence trade-off for testing new materials and structures in complex machines?

Would you tell me, please, which way I ought to go from here?"

"That depends a good deal on where you want to get to."

"I don't much care where —"

"Then it doesn't matter which way you go."

— Lewis Carroll, *Alice in Wonderland*



Thank You for Listening

And remember.....

Imagination is the only weapon in the war against reality.”
— Lewis Carroll, *Alice in Wonderland*

